

No.

SIALON THERMOCOUPLE PROTECTION TUBE for molten aluminum

Features

- High density, high strength, engineered ceramic.
- Excellent chemical stability prevents molten aluminum contamination.
- Surface treatments are not required.
- Provides cost-effective performance through **long life** and reduced maintenance.

Standard Shape and Dimensions

Standard Shape

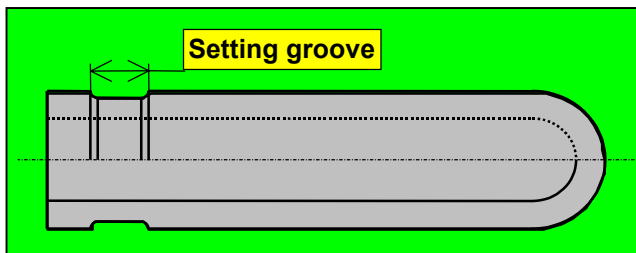

Standard Dimensions (mm)

Outer diameter	Inner diameter	Setting groove	Maximum Length
11.5	6.5	10	500
15	9	10	850
22	14	13	950
28	16	13	1100
32	20	13	1800

* Customized shapes and sizes are available.

Appearance



Standard Thermocouple Attachment Assemblies

S-type (straight)



L-type (right angle)



* Adapter and extension tube can be designed on request.

Handling and Maintenance

Reasonable care enhances the performance and lifetime of Sialon ceramic products.

Handling Precautions

- Avoid severe mechanical impact.
- Avoid rapid cooling over wide temperature range.
- Assemble and install only in moisture free conditions.

Periodic Maintenance

- Remove surface slag deposits before solidification from protection tube weekly.

*Since 1986, more than
30,000 pieces sold all over the world*

Hitachi Metals America, Ltd.

No.

SIALON STALK TUBE for low-pressure aluminum casting

Features

- High density, high-strength, engineered ceramic.
- Light weight.
- Superior chemical stability prevents molten aluminum contamination.
- Provides cost-effective performance through **long life** and reduced maintenance.

Appearance



Standard Shape and Dimensions

Standard Shape

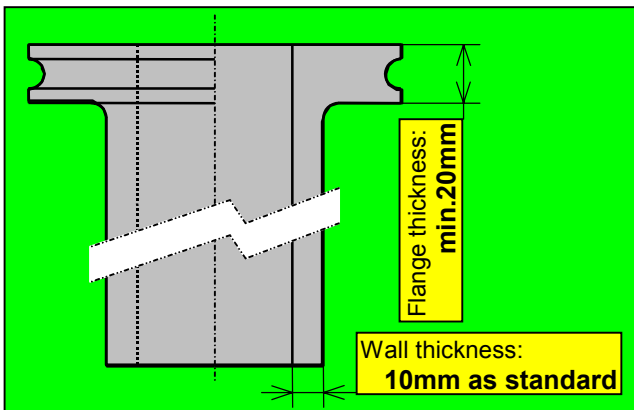

Standard Dimensions (mm)

Inner diameter	Max. length
50	1000
60	1100
70	1050
80	720
90	1350
100	1300
110	1250
120	1400
150	1100

* Customized shapes & sizes are available.

Statistics

Customer	Components delivered	Average life (yr.)
T	500	2.5
N	200	2.5
H	100	2.5

Handling and Maintenance

Reasonable care enhances the performance and lifetime of Sialon ceramic products.

Handling Precautions

- Avoid severe mechanical impact.
- Avoid rapid cooling over a wide temperature range.
- Assemble and install only in moisture free conditions.

Periodic Maintenance

- Remove slag deposits before solidification from stalk tube surface weekly.

Improper installation of seals may cause failure due to mechanical stress.

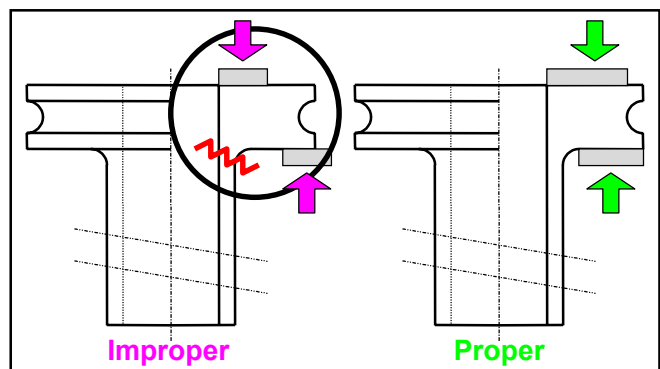

Since 1988, more than 5,000 pieces sold all over the world

* The data in our report does not constitute any kind of warranty or guarantee.

Hitachi Metals America, Ltd.

No.

SIALON HEATER SHEATH for molten aluminum

Features

- High density, high strength, engineered ceramic.
- Excellent chemical stability prevents molten aluminum contamination.
- Adaptable to both gas and electric furnaces.
- Provides cost-effective performance through **long life** and reduced maintenance.

Standard Shape and Dimensions

Standard Shape

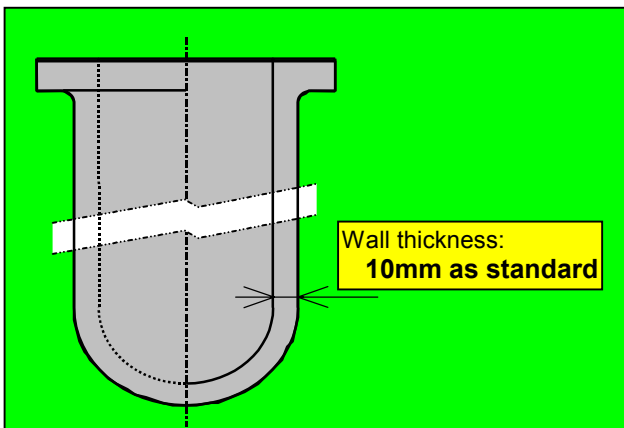

Standard Dimensions (mm)

Inner diameter	Max. length
65	1000
70	850
80	1100
85	1100
100	1250
125	850
135	1350
150	1050
165	1050
210	1150

- * Customized shapes and sizes are available.
- * Where required, metal flange construction is also available.

Appearance



Handling and Maintenance

Reasonable care enhances the performance and lifetime of Sialon ceramic products.

Handling Precautions

- Follow "break in" procedures in the instruction manual for first time use.
- Avoid severe mechanical impact.
- Avoid rapid cooling over a wide temperature range.
- Assemble and install only in moisture free conditions.

Periodic Maintenance

- Remove slag deposits before solidification from heater sheath weekly.

Statistics

Customer	Components delivered	Average life (yr.)
P	500	3
T	300	3
H	100	3

Since 1988, more than 2,000 pieces sold all over the world

- * The data in our report does not constitute any kind of warranty or guarantee.

Hitachi Metals America, Ltd.